

EFEKTYWNY™ avloppsluftare

a cost-effective and chemical-free method to stop corrosion

There oxygenation by aeration was not previously been used functions EFEKTYWNY™ avloppsluftare due to the high oxygenation rate. Oxygenation with EFEKTYWNY™ provides up to 100% better oxygenation degree in comparison with other aeration methods.

Hydrogen sulphide

When there is no oxygen in the wastewater produced sulfide. In addition to submitting smelly and hazardous gas, so damaged also concrete, metals and electrical equipment. The higher concentration, the greater the damage. In addition, it means increased operating costs for treatment plant due to increased sludge volume and higher consumption of precipitation chemicals..

Applications

Transmission line (pumping stations)
LTA / LPS system
Leachate Ponds
Stormwater Systems
Process Industry

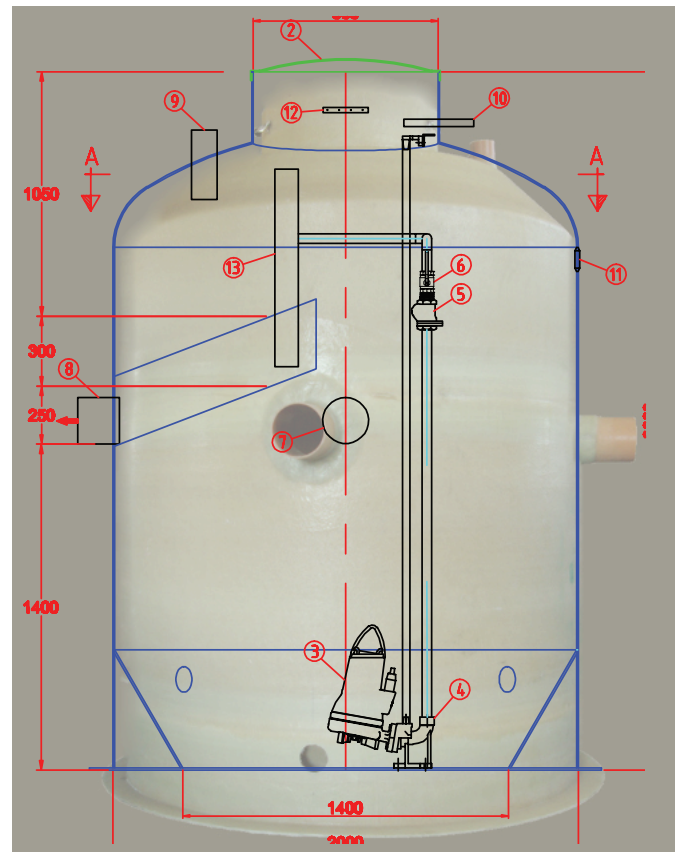
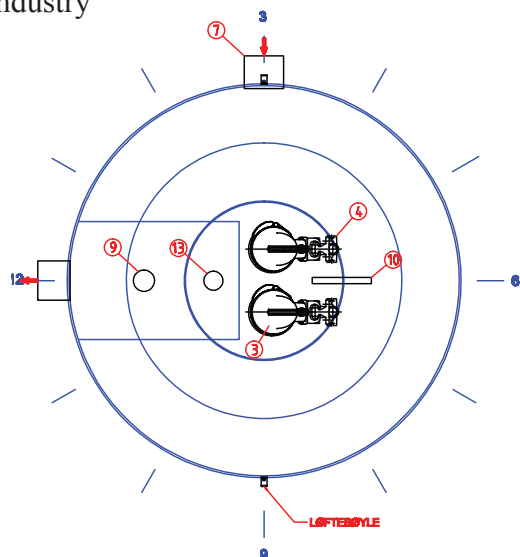

1. Pump Brown Ø 2000mm height 3000mm.
2. Lid Ø 800mm.
3. Pump.
4. Pumpfot.
5. Check valve..
6. Kulventil.
7. Inlet Ø 200mm PVC.
8. Outlet Ø 200mm PVC.
9. Ventilation Ø 110mm PVC.
10. Air in Ø 80mm.
11. Cable Inventory Ø 75mm.
12. Hanger for floats.
13. Luftare Efektywny™

